

**Ritzwell**  
EXPERIENCE JAPAN

THE COLLECTION | NEWS 2021

# BEYOND THE BOUNDARIES OF TIME AND SPACE

Since 1992, tradition and modernity have been converging in Ritzwell work. We create furniture that embodies comfort and refined elegance, made of quality materials and precious details. Reaching beyond the boundaries of time and space, it combines Japanese culture and sensitivity with a minimalist design and an international flair. Each inspiration derives from a careful attention towards the other and a meticulous study of every detail in designing artistic creations that can conquer people's hearts and find their space in everyday life. We want to offer organic and warm products that stimulate our deepest feelings and instinct, the way music and art do. Our furniture lives and ages with us, regaining that inner balance which is indispensable for anyone living in our modern societies. Since the foundation of the Ritzwell brand, we have been focusing on bringing together technology and manual work. Each product is an exercise in style, an expression of highly skilled craftsmanship.

## CREATED BY THE HANDS OF JAPANESE ARTISANS

Every Ritzwell product encloses a deep thought aimed at generating wellbeing. An accurate design project outlines the shape, while the expert manual skill of our craftsmen transforms it with extreme care into a precious object where flawless execution is crucial. We produce furniture that not only responds to the needs of function and aesthetics, but also to the needs of the soul, which recognises their harmony and perceives the 'memory of the hands' that created every detail. We select only high-quality materials such as solid wood, leather, the softest hides, and most versatile natural fabrics. The metal structures are equipped with precious and resistant finishes made vibrant by a carefully studied colour range. Our main concern is making sure that every piece preserves its beauty season after season, as it acquires a fascinating furubi or 'patina of time' which makes items unique and conceived to be handed down from generation to generation.



## QUALITY

Technology and craftsmanship coexist at Ritzwell: technology guarantees the best production methods and long-lasting products, while handcrafted finishings are an expression of the artisan skills found in haute couture workshops. As a result, the brand's appeal continues to grow among architects and interior designers, also because of its vast range of high-end projects for private dwellings and commercial spaces. Shinsaku Miyamoto and Atelier D.Q. in their dual role of designers and art directors of the brand have always matched research into style with research into materials, which are must-haves in products of excellence. At the company-cum-workshop every product is a new, fundamental step in the company mission: to disseminate the aesthetic concept of beauty, in keeping with Japanese tradition, and to deliver a perfect example of design that is all about simple harmony, pure equilibrium and an unmistakable style.

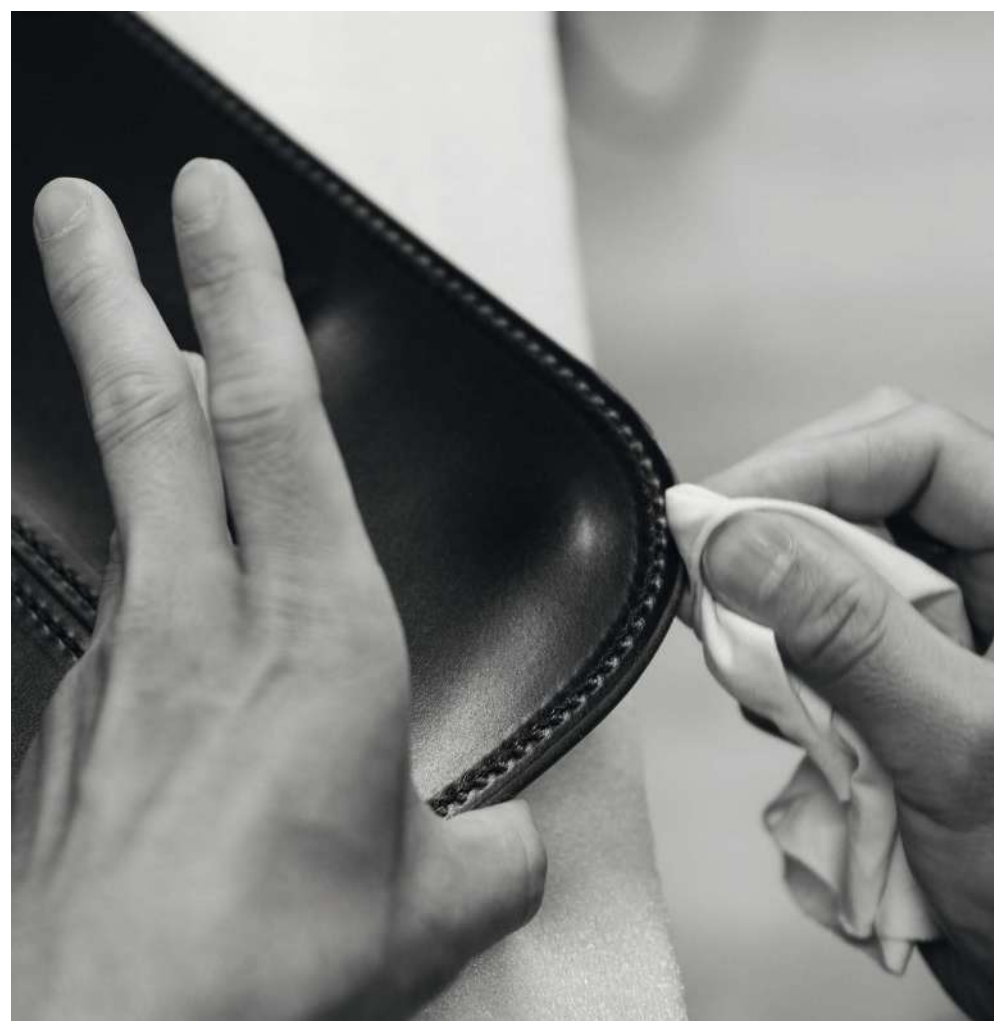



**CHAIRS, STOOLS AND DESK**

12 | MT BENCH 18 | MO BRIDGE 24 | RIVAGE 38 | JK 44 | BEATRIX  
48 | CLAUDE 50 | MARCEL 53 | JK 54 | BLAVA 57 | LUPIN 58 | VINCENT

**STORAGES**

30 | JABARA

**TABLES**

08 | LEEWISE EXCLUSIVE 10 | MT TABLE 14 | MO TABLE 40 | JK TABLE  
60 | OS TABLE 64 | MCM TABLE

**SOFAS**

08 | LEEWISE EXCLUSIVE 68 | LIGHT FIELD 74 | DIANA



1 SEATER SOFA | 2021  
FRAME: WHITE ASH POLYURETHANE FINISH (BLACK)  
CUSHION: FABRIC



OTTOMAN | 2021  
FRAME: WHITE ASH POLYURETHANE FINISH (BLACK)  
CUSHION: FABRIC



SIDE TABLE | 2021  
TOP: OAK POLYURETHANE FINISH (BLACK)  
LEG FRAME: WHITE ASH POLYURETHANE FINISH (BLACK)



3 SEATER SOFA | 2021  
FRAME: WHITE ASH POLYURETHANE FINISH (BLACK)  
CUSHION: FABRIC

**LEEWISE EXCLUSIVE** | DESIGN JUNICHIRO WATANABE & RITZWELL

MODULAR SOFA 2021  
FRAME: WHITE ASH POLYURETHANE FINISH (BLACK)  
CUSHION: FABRIC

| NEW |



THIS MODULAR SOFA FEATURES A LOW SEAT AS A REFERENCE TO THE WAY JAPANESE PEOPLE SIT ON THE TATAMI AND IS MADE PARTICULARLY COMFORTABLE BY THE SOFT AND LARGE CUSHIONS PLACED DELICATELY ON THE MODERN STRUCTURE, WHICH IS ENTIRELY MADE IN SOLID ASH. THE BACKREST AND ARMRESTS DEFINE A PARTICULARLY APPEALING STYLISTIC DETAIL. IT SPRINGS FROM A TIDY JUXTAPOSITION OF THIN WOODEN STAVES THAT SHAPE A GRID, WHICH IS A DECORATIVE AND FUNCTIONAL ELEMENT ALL AT ONCE.

**MT TABLE** | DESIGN SHINSAKU MIYAMOTO

DINING TABLE 2021

TABLE TOP: WALNUT OIL FINISH

FRAME: HAIRLINE STAINLESS STEEL (ANTIQUE GRAY)

| NEW |



THE ELEGANCE OF THIS DINING TABLE IS GENERATED BY THE BALANCE BETWEEN THE WIDE SOLID WOOD TOP AND THE SLIM METAL LEGS. THE WARMTH OF THE WOODEN ELEMENT DIALOGUES WITH THE LIGHTNESS OF THE STRUCTURE AND CREATES A DELICATE HARMONY. THE ESSENTIAL STYLE MAKES IT A PERFECT MATCH FOR BOTH TRADITIONAL AND CONTEMPORARY CHAIRS. IT CAN BE PERSONALIZED BY CHOOSING THE COLOUR OF THE STRUCTURE AND THAT OF THE WOODEN TOP.

**MT** | DESIGN SHINSAKU MIYAMOTO

BENCH 2020

SEAT: WALNUT OIL FINISH

FRAME: HAIRLINE STAINLESS STEEL (SHINY BRONZE)

BELT: THICK LEATHER (TAUPE GRAY)



**BENCH | 2020**

SEAT: OAK POLYURETHANE FINISH (BLACK)

FRAME: HAIRLINE STAINLESS STEEL (ANTIQUE GRAY)

BELT: THICK LEATHER (TAUPE GRAY)



**BENCH | 2020**

SEAT: WALNUT OIL FINISH

FRAME: HAIRLINE STAINLESS STEEL (SHINY BRONZE)

BELT: THICK LEATHER (TAUPE GRAY)

THE MT BENCH OFFERS AN INTRICATE GAME OF WEAVES AND A COMBINATION OF QUALITY MATERIALS THAT REPRESENT THE ENCOUNTER BETWEEN TRADITION AND MODERNITY. THE INTERWOVEN LEATHER STRAPS ON THE SEAT CONVEY A PLEASANT SENSATION OF WARMTH AND PERFECTLY MATCH THE STRUCTURE IN STEEL AND SOLID WALNUT OR OAK. THE ATTENTION TO DETAIL, SUCH AS THE PURE LINES AND ROUNDED EDGES OF THE SURFACE, MAKES THIS STRUCTURE A HARMONISING ELEMENT IN ANY ENVIRONMENT. THE BENCH IS AVAILABLE IN DIFFERENT COLOUR COMBINATIONS AND IN TWO SIZES.

**MO TABLE** | DESIGN SHINSAKU MIYAMOTO

DINING TABLE 2021

TABLE TOP: WALNUT OIL FINISH

LEG: OAK POLYURETHANE FINISH (BLACK)

| NEW |



**MO TABLE** | DESIGN SHINSAKU MIYAMOTO

DINING TABLE 2016

TABLE TOP AND LEG: OAK POLYURETHANE FINISH (BLACK)



**DINING TABLE | 2016**

TABLE TOP AND LEG: OAK POLYURETHANE FINISH (BLACK)



**SIDE TABLE | 2016**

TABLE TOP AND LEG: OAK OIL FINISH (WHITE)



**COFFEE TABLE | 2016**

TABLE TOP AND LEG: OAK POLYURETHANE FINISH (BLACK)

THESE TABLES BRING A WARM, GENTLE FEELING TO EVERY SCENE, WITH DELIGHTFUL LEG LINES, THE STRENGTH OF SOLID WOOD SHINES THROUGH IN THIS MODERN DESIGN. THE QUALITY LOOK AND FEEL OF NATURAL WOOD BRINGS TRANQUILLITY. THE COLLECTION COMBINES TWO TYPES OF DINING TABLE WITH ROUNDED OR RECTANGULAR TOP WITH A NUMBER OF ROUND COFFEE AND SIDE TABLES TO CREATE INFINITE NOOKS AND GATHERINGS.

**MO BRIDGE** | DESIGN SHINSAKU MIYAMOTO

BENCH 2021

| NEW |



BENCH | 2021  
FRAME: WALNUT OIL FINISH  
BELT: THICK LEATHER (TAUPE GRAY)



BENCH | 2021  
FRAME: OAK OIL FINISH (MATTE BLACK)  
BELT: THICK LEATHER (BLACK)

**MO BRIDGE** | DESIGN SHINSAKU MIYAMOTO

SQUARE BENCH 2021

FRAME: OAK POLYURETHANE FINISH (MATTE TAUPE GRAY)

BELT: THICK LEATHER (VINTAGE BROWN)

| NEW |



THE MO BRIDGE COLLECTION IS CHARACTERISED BY ELEGANCE AND SOPHISTICATION, WITH ITS SOFT LINES AND COMBINATIONS OF QUALITY MATERIALS. ANCIENT CRAFTSMANSHIP MERGES WITH MINIMAL SHAPES TO GENERATE THE CONTEMPORARY ESSENCE OF THESE PIECES. MO BRIDGE BENCH AND SQUARE BENCH ARE CHARACTERIZED BY WOODEN STRUCTURE AS WELL AS BY THE SEAT WHICH PLAYS WITH A WEAVE MADE IN PRECIOUS LEATHER.

**MO BRIDGE** | DESIGN SHINSAKU MIYAMOTO

STOOL 2020

FRAME: OAK POLYURETHANE FINISH (BLACK)

BELT: THICK LEATHER (VINTAGE BROWN)



**STOOL | 2020**

FRAME: OAK OIL FINISH (WHITE)  
BELT: THICK LEATHER (BLACK)



**STOOL | 2020**

FRAME: OAK POLYURETHANE FINISH (BLACK)  
BELT: THICK LEATHER (VINTAGE BROWN)

THE MO BRIDGE STOOL OFFERS A SEAT CRAFTED FROM FINE WOVEN LEATHER. THANKS TO ITS ESSENTIAL DESIGN, IT CAN DECORATE THE INTERIORS OF CONTEMPORARY, ELEGANT AND COMFORTABLE LIVING SPACES IN ANY STYLE, BUT IT IS ALSO PERFECT FOR FURNISHING SHOWROOMS AND HOTELS. CARE FOR DETAILS AND PRECISION ENCOUNTER CRAFTSMANSHIP AND RESEARCH.

**MO BRIDGE** | DESIGN SHINSAKU MIYAMOTO

SMALL DESK 2020

TOP: WALNUT OIL FINISH | THICK LEATHER (DARK BROWN)

FRAME: WALNUT OIL FINISH



THE DESK COMBINES PURE VOLUMES IN SOLID WALNUT OR OAK WITH A FINE DECORATIVE SURFACE IN SMOOTH LEATHER. THE ANCESTRAL MEMORIES OF THE 'ARTISANAL KNOW-HOW' OF THE PAST BECOME ONE WITH ESSENTIAL LINES THAT DEFINE THE CONTEMPORARY NATURE OF THIS PIECE.



**SMALL DESK | 2020**

TOP: OAK POLYURETHANE FINISH (BLACK) | THICK LEATHER (VINTAGE BROWN)

FRAME: OAK POLYURETHANE FINISH (BLACK)



**RIVAGE** | DESIGN ATELIER D.O.  
LOUNGE CHAIR 2020  
FRAME: STEEL (BLACK) | ARM: WALNUT OIL FINISH | SEAT AND BACK: LEATHER



LOUNGECHAIR | 2020  
FRAME: STEEL (BLACK)  
ARM: OAK OIL FINISH (WHITE)  
SEAT AND BACK: LEATHER



THE RIVAGE LOUNGE CHAIR IS COMPOSED BY A STEEL STRUCTURE WHICH IS COMBINED WITH A SOFT SEAT. THE CONTEMPORARY AND APPEALING DESIGN OF THIS PRODUCT CONVEYS A SENSE OF CALM, RELAXATION, SOLIDITY AND SAFETY. THE COMFORTABLE ARMRESTS IN WALNUT OR OAK DRAW INSPIRATION FROM THE TYPICAL CURVED SHAPE OF THE ROOFS OF JAPANESE TEMPLES AND SHRINES. THANKS TO THE VARIOUS FINISHES AND SHADES AVAILABLE, THE RIVAGE ARMCHAIR FITS PERFECTLY INTO ANY LIVING SPACE.



**RIVAGE** | DESIGN ATELIER D.O.  
EASY CHAIR 2011  
FRAME: WALNUT OIL FINISH | SEAT AND BACK: LEATHER



**ARMCHAIR | 2011**  
FRAME: WALNUT OIL FINISH  
SEAT AND BACK: LEATHER



**EASY CHAIR | 2016**  
FRAME: WALNUT OIL FINISH  
SEAT AND BACK: LEATHER



**STOOL | 2016**  
FRAME: OAK POLYURETHANE FINISH (BLACK)  
SEAT: LEATHER



**JABARA** | DESIGN SHINSAKU MIYAMOTO

SIDEBOARD 2018

BODY: OAK POLYURETHANE FINISH | BASE: HAIRLINE STAINLESS STEEL (SHINY BRONZE)

FRONT DRAWER: THICK LEATHER | DOOR: SLIDING TAMBOUR DOOR



**SIDEBOARD | 2018**

BODY: OAK POLYURETHANE FINISH (WHITE)  
BASE: STEEL (BLACK)



**SIDEBOARD | 2018**

BODY: WALNUT POLYURETHANE FINISH  
BASE: STEEL (BLACK)



**SIDEBOARD | 2018**

BODY: WALNUT POLYURETHANE FINISH  
BASE: STEEL (BLACK)



THE JABARA SIDEBOARD USES DISTINCTIVE SLIDING TAMBOUR DOORS IN A MODERN, MINIMALIST FORM. THE FEELING OF UNEVENNESS THAT COMES FROM SOLID WOOD THAT HAS BEEN CUT OFF INTO THIN STRIPS AND GIVEN A ROUNDED SURFACE, AND THE SENSIBILITY OF THE CRAFTSMAN IN DISCERNING THE ESSENTIAL NATURE OF THE SOLID WOOD, COMBINE TO GIVE RISE TO MAGICAL SHADOWS AND A WARM, PROFOUND EXPRESSIVENESS IN THE ENTIRE PRODUCT. THICK LEATHER WITH A NATURAL TEXTURE, PAINSTAKINGLY TANNED USING VEGETABLE TANNIN, IS USED ON THE SURFACE OF THE DRAWERS. THE LEATHER COMPLEMENTS THE LUXURIOUSNESS AND PLEASURE OF THE PRODUCT AS A WHOLE.





## JABARA | DESIGN SHINSAKU MIYAMOTO

AV BOARD 2019

BODY: WALNUT POLYURETHANE FINISH | BASE: STEEL (BLACK) AND HAIRLINE STAINLESS STEEL (ANTIQUE BRASS)

DOOR: SLIDING TAMBOUR DOOR AND GLASS FLAP DOOR



red dot design award  
best of the best 2019



JABARA AV BOARD IS A CABINET FOR AUDIO-VISUAL EQUIPMENT CONCEIVED TO ELEGANTLY AND FLEXIBLY INSERT ITSELF INTO THE CONTEMPORARY HOME THANKS TO ITS MANY VARIATIONS IN SIZE AND STRUCTURE. ONE OR SEVERAL STORAGE COMPARTMENTS FEATURING TAMBOUR WOODEN DOORS ARE ALTERNATED WITH AN AREA DESIGNED FOR TECHNOLOGICAL COMPONENTS. THE LATTER, WHICH IS IDENTIFIED BY A TILT AND TURN DOOR IN DARK TINTED GLASS, INTRODUCES A STRONG COMPOSITIONAL ELEMENT WHICH - BY CONTRAST - HIGHLIGHTS THE JAPANESE AESTHETICS OF THE SLIM VERTICAL LINES OF THE TAMBOUR DOORS, TYPICAL OF THE YOSHIDO CANE DOORS AND THE SAGANO BAMBOO FORESTS IN KYOTO.



**AV BOARD | 2019**  
BODY: OAK POLYURETHANE FINISH (WHITE)  
BASE: STEEL (BLACK)



**AV BOARD | 2019**  
BODY: WALNUT POLYURETHANE FINISH  
BASE: STEEL (BLACK)



**AV BOARD | 2019**  
BODY: OAK POLYURETHANE FINISH (WHITE)  
BASE: STEEL (BLACK)

**JK** | DESIGN JUN KAMAHARA

EASY CHAIR 2019

FRAME: HAIRLINE STAINLESS STEEL (CLASSIC ROSE) AND LEATHER (BLACK)

SEAT AND BACK: THICK LEATHER (BLACK) | CUSHION: LEATHER



THE JK EASY CHAIR IS COMPOSED BY A THIN TUBULAR FRAME IN STAINLESS STEEL SUPPORTING A DEEP LEATHER SEAT. THE BACKREST IS MADE OF LEATHER STRIPS PADDED WITH LARGE CUSHIONS WHICH HAVE BEEN SPECIFICALLY DESIGNED TO DELICATELY HOST THE PERSON'S HIPS AND PROVIDE A COMFORTABLE SUPPORT FOR THE BACK. THE COMFORT GRANTED BY THIS CHAIR IS ALMOST SURPRISING CONSIDERING THE HIGHLY GRAPHIC APPEARANCE OF THE OBJECT. ALL THE MATERIALS AND FINISHES HAVE BEEN CHOSEN FOR THEIR CAPACITY TO BECOME MORE BEAUTIFUL SEASON AFTER SEASON AND ACQUIRE THE FAMOUS "GLAZE OF TIME" (FURUBI IN JAPANESE).



**EASY CHAIR | 2019**

FRAME: HAIRLINE STAINLESS STEEL (CLASSIC ROSE) AND LEATHER (BLACK)

SEAT AND BACK: THICK LEATHER (BLACK)

CUSHION: LEATHER



**EASY CHAIR | 2019**

FRAME: HAIRLINE STAINLESS STEEL (CLASSIC ROSE) AND LEATHER (BLACK)

SEAT AND BACK: THICK LEATHER (BLACK)

CUSHION: LEATHER

**JK TABLE** | DESIGN JUN KAMAHARA

COFFEE TABLE 2004

TABLE TOP: WALNUT OIL FINISH | LEG: HAIRLINE STAINLESS STEEL (SHINY BRASS)



COFFEE TABLES | 2004  
TABLE TOP: WALNUT OIL FINISH  
LEG: STEEL (BLACK)

**JK TABLE** | DESIGN JUN KAMAHARA

SIDE TABLE 2019

TABLE TOP: WALNUT OIL FINISH | LEG: STEEL (BLACK) AND HAIRLINE STAINLESS STEEL



**SIDE TABLE | 2019**

TABLE TOP: WALNUT OIL FINISH

LEG: HAIRLINE STAINLESS STEEL (SHINY BRONZE)



**SIDE TABLE | 2019**

TABLE TOP: WALNUT OIL FINISH

LEG: HAIRLINE STAINLESS STEEL (ANTIQUÉ BRASS)



AVAILABLE IN TWO VERSIONS, WITH A SQUARED AND CIRCULAR TOP, JK SIDE TABLES ARE CHARACTERISED BY A PARTICULAR LIGHTNESS THANKS TO THE SLIM SECTION OF THE TOP IN SOLID WALNUT AND THE STEEL POWDER COATING STRUCTURE AND HAIRLINE STAINLESS STEEL ACRYLIC URETHANE COATING STRUCTURE. THEIR MINIMALIST DESIGN IS EMBELLISHED BY THE SLIGHTLY UPWARD CURVING CORNERS OF THE SQUARED TOP AND BY THE BEVELLED EDGE OF THE CIRCULAR VERSION.

**BEATRIX** | DESIGN SHINSAKU MIYAMOTO  
HIGH BACK EASY CHAIR 2017 AND OTTOMAN 2018

FRAME: WALNUT OIL FINISH | SEAT AND BACK: FABRIC | SHELL: THICK LEATHER (DARK BROWN)



reddot design award  
winner 2019



CONSISTING OF A VARIETY OF ELEMENTS, THE BEATRIX HIGH-BACK EASY CHAIR WAS DEVELOPED OVER MANY YEARS OF EXPERIMENTATION, ON THE BASIS OF THE AESTHETIC SENSIBILITIES AND SUPERIOR TECHNOLOGICAL PROWESS OF JAPAN. THE EXCEPTIONAL CONSCIENTIOUSNESS AND ATTENTION TO DETAIL OF JAPANESE CRAFTSPEOPLE ARE NECESSARY FOR THE CHAIR'S PRODUCTION. ALTHOUGH THIS CHAIR IS NOT SUITED TO MASS PRODUCTION, IN ORDER TO MAKE SOMETHING THAT RESONATES WITHIN THE HEART OF THE USER, WE BELIEVE IT IS ESSENTIAL TO MAKE THAT ITEM BY HAND, ONE BY ONE, WITH LOVING CARE.



**HIGH BACK EASY CHAIR | 2017**

FRAME: WALNUT OIL FINISH  
SEAT AND BACK: LEATHER  
SHELL: THICK LEATHER (BLACK)



**HIGH BACK EASY CHAIR | 2020**

FRAME: WALNUT OIL FINISH  
SEAT AND BACK: FABRIC  
SHELL: FABRIC  
PIPING: LEATHER



**HIGH BACK EASY CHAIR | 2017 AND OTTOMAN | 2018**

FRAME: WALNUT OIL FINISH  
SEAT AND BACK: LEATHER  
SHELL: THICK LEATHER (BLACK)



**CLAUDE** | DESIGN SHINSAKU MIYAMOTO

EASY CHAIR 2013

FRAME: WALNUT OIL FINISH | SEAT AND BACK: LEATHER



THE DETAILING ON THE SCULPTURED ARMRESTS AND THE LINES OF THE LEGS ARE UNIQUE, AND ESPECIALLY THE FLAWLESS CARVING OF THE ARMRESTS SUGGESTS THE ANCIENT STATUES OF BUDDHA, CREATING A TOOLED YET EVEN FINISH. THE POWERFUL DESIGN ENCOMPASSES TRANQUILITY AND QUIETUDE... A DESIGN THAT COMBINES OLD ELEMENTS INTO SOMETHING STUNNINGLY NEW.



**CHAIR | 2016**  
FRAME: OAK OIL FINISH (WHITE)  
SEAT AND BACK: LEATHER



**ARMCHAIR | 2013**  
FRAME: WALNUT OIL FINISH  
SEAT AND BACK: FABRIC



**EASY CHAIR | 2016**  
FRAME: OAK POLYURETHANE FINISH (MATTE BLACK)  
SEAT AND BACK: LEATHER



**CHAIR | 2016**

FRAME: OAK OIL FINISH (WHITE)  
BACK PANEL: OAK POLYURETHANE FINISH (BLACK)  
SEAT AND BACK: LEATHER



**CHAIR | 2013**

FRAME: WALNUT OIL FINISH  
BACK PANEL: WALNUT POLYURETHANE FINISH  
SEAT AND BACK: LEATHER



**CHAIR | 2016**

FRAME: OAK POLYURETHANE FINISH (MATTE BLACK)  
BACK PANEL: OAK POLYURETHANE FINISH (MATTE BLACK)  
SEAT AND BACK: LEATHER



THE FORM FULLY UTILIZES MODERN WOODWORKING TECHNOLOGY, COMBINED WITH THE EXPERTISE AND EXPERIENCE OF DESIGNERS WHO TRULY UNDERSTAND WOOD AND ITS CHARACTERISTICS. THE NATURAL FEEL OF THE BASIC WALNUT IS PRESERVED, BRINGING OUT THE WARMTH OF THE WOOD, AND THE BEAUTIFUL LINE FROM THE REAR LEGS UP THROUGH THE BACK ENFOLDS YOU IN GENTLE ELEGANCE.

**JK** | DESIGN JUN KAMAHARA

ARMCHAIR 2004

FRAME: WALNUT OIL FINISH | SEAT: LEATHER | BACK: THICK LEATHER (BLACK)



**DETAIL | ARMCHAIR | 2016**

FRAME: OAK OIL FINISH (WHITE)

SEAT: LEATHER

BACK: THICK LEATHER (BLACK)



**BLAVA** | DESIGN ATELIER D.O.

EASY CHAIR 2007

FRAME: WALNUT OIL FINISH | CUSHION: LEATHER | BELT: THICK LEATHER (BLACK)



**HIGH BACK EASY CHAIR | 2016**

FRAME: OAK POLYURETHANE FINISH (BLACK)

CUSHION: FABRIC

BELT: THICK LEATHER (BLACK)



**OTTOMAN | 2016**

FRAME: OAK POLYURETHANE FINISH (BLACK)

CUSHION: FABRIC

BELT: THICK LEATHER (BLACK)



**EASY CHAIR | 2016**

FRAME: OAK OIL FINISH (WHITE)

CUSHION: LEATHER

BELT: THICK LEATHER (BLACK)

**LUPIN** | DESIGN ATELIER D.O.

LOUNGE CHAIR 2014

FRAME: WALNUT OIL FINISH AND THICK LEATHER (BLACK) | PADDING AND CUSHION: LEATHER



THE SQUARE FORM OF THE SOFA IMPARTS A FEELING OF RELAXATION AND COMFORT. WHILE COMPOSED OF FLAT SURFACES ON THREE SIDES IT EVOLVES INTO A THREE-DIMENSIONAL FORM RICH IN ORGANIC BEAUTY. THE LUXURIOUS BASE OF THICK LEATHER IS ACCENTUATED WITH A BELT DESIGN BRINGING OUT THE FULL BEAUTY OF THE MATERIALS. THE INTERPLAY OF LIGHT AND SHADOW ON THE DELICATE TEXTURE REVEALS ITS QUIET, REFINED FEEL. ALVAR AALTO ONCE SAID, "THE FURNITURE, THE FABRICS, THE COLOR SCHEMES AND THE STRUCTURES CAN BE EARNESTLY AND HAPPILY MADE SO THAT THEY PRODUCE NO CONTRAST TO THE TRAGEDY AND COMEDY OF HUMAN LIFE". AND IN KEEPING WITH HIS PHILOSOPHY OUR SOFA INCORPORATES SOFTNESS INTO ITS VERY DESIGN FOR SATISFYINGLY DEEP COMFORT AND RELAXATION.

STOOL 2016

FRAME: OAK POLYURETHANE FINISH (BLACK) | BELT: THICK LEATHER (BLACK)



STOOL | 2011

FRAME: WALNUT OIL FINISH  
BELT: THICK LEATHER (VINTAGE BROWN)



STOOL | 2016

FRAME: OAK POLYURETHANE FINISH (BLACK)  
BELT: THICK LEATHER (BLACK)



STOOL | 2016

FRAME: OAK OIL FINISH (WHITE)  
BELT: THICK LEATHER (BLACK)



**OS TABLE** | DESIGN RITZWELL

SIDE TABLE 2014

TABLE TOP: WALNUT OIL FINISH AND OAK POLYURETHANE FINISH (BLACK)

LEG: STEEL (BLACK) AND HAIRLINE STAINLESS STEEL (6 COLORS)



**SIDE TABLE | 2016**

TABLE TOP: OAK POLYURETHANE FINISH (BLACK)

LEG: STEEL (BLACK)



**SIDE TABLE | 2016**

TABLE TOP: OAK OIL FINISH (WHITE)

LEG: STEEL (BLACK)



**MCM TABLE** | DESIGN SHINSAKU MIYAMOTO

DINING TABLE 2015

TABLE TOP AND LEG: WALNUT OIL FINISH | FRAME: STEEL (BLACK)



ONLY SUPPORTED BY FOUR LEGS, ITS SIMPLE DESIGN HIGHLIGHTS THE THINNESS OF THE TABLE TOP. THIS SUPERB, MODERN LOOKING LONG SIZE TABLE COMBINES STRENGTH AND DESIGNABILITY. ITS DETAILED DESIGN, WHICH ADDS TO THE WONDERFUL APPEARANCE AND ROUNDNESS OF A WOOD GRAIN TABLE TOP THAT CAN ONLY BE CREATED WITH NATURAL WOOD, ALSO ALLOWS ONE TO FEEL THE STRONG PRESENCE AND GENTLENESS THAT WOOD POSSESSES, AS WELL AS BRINGING A BEAUTIFUL BALANCE TO COMFORTABLE, RELAXING SPACES.





**LIGHT FIELD** | DESIGN SHINSAKU MIYAMOTO

MODULAR SOFA 2014

FRAME: FABRIC, LEATHER AND THICK LEATHER COVERED PANELS

PADDING AND CUSHION: FABRIC AND LEATHER

LEG: STEEL (BLACK) AND HAIRLINE STAINLESS STEEL (6 COLORS)



THE LUXURIOUS CUSHION ENSURES RELAXATION, WHILE THE STRIKING LEATHER FORM IS LIGHT, AIRY. THIS EXQUISITE PIECE OFFERS A DELICATE BALANCE OF QUIETUDE AND TENSION. THE THICK LEATHER IS PREPARED WITH TANNIN TO BRING OUT ITS FULL BEAUTY, AND STITCHED WITH CARE TO LEVERAGE THE QUALITY OF THE HIGH-GRADE MATERIALS INTO A MASTERPIECE OF UNDERSTATEMENT. FABRIC CUSHIONS ENFOLD YOU IN COMFORT, ADDING SOFTNESS TO THE WHOLE AND REALIZING A BOLD AND ELEGANT ADDITION TO YOUR ROOM.



**1 SEATER SOFA | 2014**

FRAME: THICK LEATHER COVERED PANELS (BLACK)

PADDING AND CUSHION: FABRIC AND LEATHER

LEG: STEEL (BLACK)



**3 SEATER SOFA | 2014**

FRAME: THICK LEATHER COVERED PANELS (BLACK)

PADDING AND CUSHION: LEATHER

LEG: HAIRLINE STAINLESS STEEL (ANTIQUE GRAY)

**DETAIL | 1 SEATER SOFA | 2014**  
FRAME: THICK LEATHER COVERED PANELS (BLACK)  
PADDING AND CUSHION: FABRIC



**3 SEATER SOFA | 2014**  
FRAME: THICK LEATHER COVERED PANELS  
PADDING AND CUSHION: FABRIC  
LEG: HAIRLINE STAINLESS STEEL (SHINY HAIRLINE)



**ANGULAR SOFA | 2014**  
FRAME: THICK LEATHER COVERED PANELS  
PADDING AND CUSHION: FABRIC AND LEATHER  
LEG: HAIRLINE STAINLESS STEEL (SHINY HAIRLINE)



**DIANA** | DESIGN SHINSAKU MIYAMOTO

1 SEATER SOFA 2015

FRAME: WALNUT OIL FINISH | FRAME COVER: LEATHER | CUSHION: LEATHER



1 SEATER SOFA | 2015  
FRAME: WALNUT OIL FINISH  
FRAME COVER AND CUSHION: LEATHER

THE CHARACTERISTIC LINE OF THE BACK AND ARM FRAME, CURVING TO ENCOMPASS YOUR BODY, GIVES THE DESIGN A POWERFUL VISUAL IMPACT COMBINED WITH THE UNIQUE TRANQUILITY OF JAPAN. THE LEATHER WRAPPINGS ON THE FRAME ADJUST THE FEEL OF THE WOOD, BRINGING ITS WILD NATURE UNDER CONTROL AND CAMOUFLAGING ITS FORM TO MAKE THE WALNUT STAND OUT EVEN MORE. THE HUES OF THE LEATHER ARE AS CLOSE TO NATURAL AS POSSIBLE, BALANCING WELL WITH THE WALNUT AS NO INORGANIC, UNIFORM COLOR COULD. THE FUSION OF WALNUT AND LEATHER CREATES A HIGH-GRADE FEEL, AND EXPRESSES THE AMBIANCE OF JAPAN THROUGH WOOD, LEATHER AND CLOTH.



**3 SEATER SOFA | 2013**  
FRAME: WALNUT OIL FINISH  
FRAME COVER: LEATHER  
CUSHION: FABRIC



**3 SEATER SOFA | 2016**  
FRAME: OAK OIL FINISH (WHITE)  
FRAME COVER AND CUSHION: LEATHER



**OTTOMAN | 2016**  
FRAME: OAK OIL FINISH (WHITE)  
FRAME COVER AND CUSHION: LEATHER



**3 SEATER SOFA | 2013**  
FRAME: WALNUT OIL FINISH  
FRAME COVER: LEATHER  
CUSHION: FABRIC

## ITOSHIMA SEASIDE FACTORY

Itoshima Seaside Factory is set in the heart of a pine forest overlooking the beauty of the Genkai Sea. This is the core of our manufacturing process, focused on hand worked upholstery and the sewing stage of production. In a time when cost and efficiency are commonly prioritized during manufacturing, we, instead, have chosen to value and spare no effort in our reliable creative process. The refined space of the building offers both functionality and a warm atmosphere and is built on a strong belief in the brand concept—that the aesthetic sensitivity and skills of trained craftspeople are cultivated if immersed in pleasant surroundings. Here young artisans earnestly create their unique pieces, making full use of the latest technology as well as of a strict hand-crafting process. Every day is spent in a top-quality and calm atmosphere, where people work and, at the same time, enjoy the scent of the sea carried by wind blowing through the trees, and the sound of waves rolling in on the sandy beach.



44 |

**BEATRIX**

Design: SHINSAKU MIYAMOTO  
 Seat and back in fabric and leather  
 Frame in walnut, oak  
 Shell in thick leather  
 Black, burgundy, vintage brown, taupe gray and dark brown thick leather

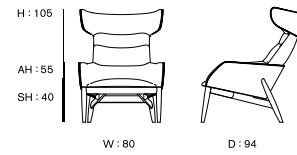

HIGH BACK EASY CHAIR

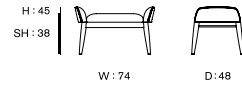

OTTOMAN

48 |

**CLAUDE**

Design: SHINSAKU MIYAMOTO  
 Seat and back in fabric and leather  
 Frame in walnut, oak

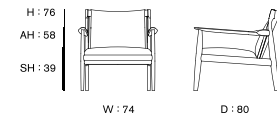

EASY CHAIR

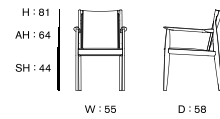

ARMCHAIR

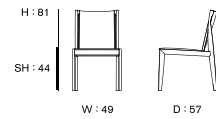

CHAIR

50 |

**MARCEL**

Design: SHINSAKU MIYAMOTO  
 Seat and back in fabric and leather  
 Frame in walnut, oak

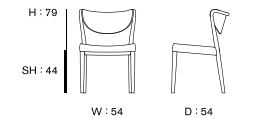

CHAIR

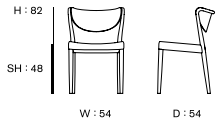

CHAIR

24 |

**RIVAGE**

Design: ATELIER D.O.  
 Seat and back in fabric and leather  
 Frame in walnut, oak for EASY CHAIR, ARMCHAIR, STOOL  
 steel powder coating with black and hairline stainless  
 teal acrylic urethane coating with 6 colors for LOUNGE CHAIR,  
 classic rose, shiny brass, antique brass, shiny bronze,  
 antique gray and shiny hairline  
 Arm in walnut, oak for LOUNGE CHAIR

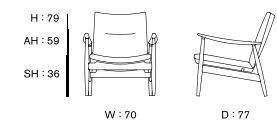

EASY CHAIR

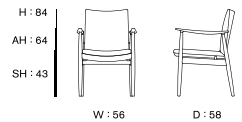

ARMCHAIR

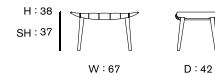

STOOL



LOUNGE CHAIR

53 | 39 |

**JK**

Design: JUN KAMAHARA  
 Seat in fabric and leather for ARMCHAIR  
 and thick leather for EASY CHAIR  
 Back in thick leather  
 Natural, black, burgundy, vintage brown, taupe gray  
 and dark brown thick leather  
 Frame in walnut, oak for ARMCHAIR and hairline stainless  
 steel acrylic urethane coating with 6 colors for  
 EASY CHAIR, classic rose, shiny brass, antique brass,  
 shiny bronze, antique gray and shiny hairline

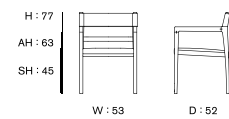

ARMCHAIR



EASY CHAIR

54 |

**BLAVA**

Design: ATELIER D.O.  
 Seat and back in removable fabric and leather  
 Belt in thick leather  
 Natural, black, burgundy, vintage brown, taupe gray  
 and dark brown thick leather  
 Frame in walnut, oak

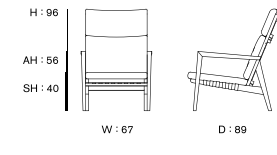

HIGH BACK EASY CHAIR

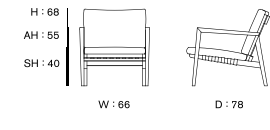

EASY CHAIR

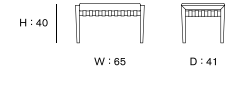

OTTOMAN

57 |

**LUPIN**

Design: ATELIER D.O.  
 Seat and back in fabric and leather  
 Frame in walnut, oak  
 Outside of seat and back in thick leather  
 Natural, black, burgundy, vintage brown, taupe gray  
 and dark brown thick leather

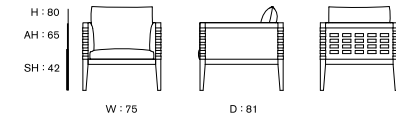

LOUNGE CHAIR

22 | 20 | 18 |

**MO BRIDGE**

Design: SHINSAKU MIYAMOTO  
 Seat in walnut, oak with thick leather webbing  
 Natural, black, burgundy, vintage brown, taupe gray  
 and dark brown thick leather  
 Frame in walnut, oak  
 Top in walnut, oak upholstered in thick leather  
 Natural, black, burgundy, vintage brown, taupe gray  
 and dark brown

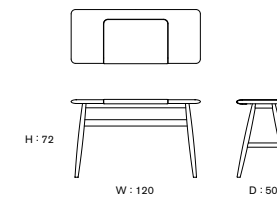

SMALL DESK



STOOL

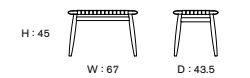

STOOL

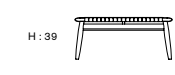

SQUARE BENCH



BENCH

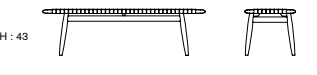

BENCH

12 |

**MT**

Design: SHINSAKU MIYAMOTO  
 Seat in walnut, oak with thick leather webbing  
 Natural, black, burgundy, vintage brown, taupe gray  
 and dark brown thick leather  
 Frame in steel powder coating with black  
 and hairline stainless steel acrylic urethane coating  
 with 6 colors, classic rose, shiny brass, antique brass,  
 shiny bronze, antique gray and shiny hairline

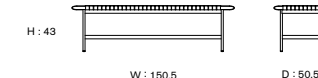

BENCH

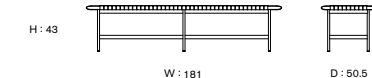

BENCH

58 |

**VINCENT**

Design: RITZWELL  
 Seat with thick leather webbing  
 Natural, black, burgundy, vintage brown, taupe gray  
 and dark brown thick leather  
 Frame in walnut, oak



STOOL

68 |

**LIGHT FIELD**

Design: SHINSAKU MIYAMOTO

Seat and back cushion in removable fabric and upholstered fixed leather

Outer panel in removable fabric, leather and upholstered fixed thick leather

Leg in steel powder coating with black and hairline stainless steel acrylic urethane coating with 6 colors, classic rose, shiny brass, antique brass, shiny bronze, antique gray and shiny hairline

Thick leather available in black, burgundy, vintage brown, taupe gray and dark brown thick leather

- - - - Sewing scheme in leather

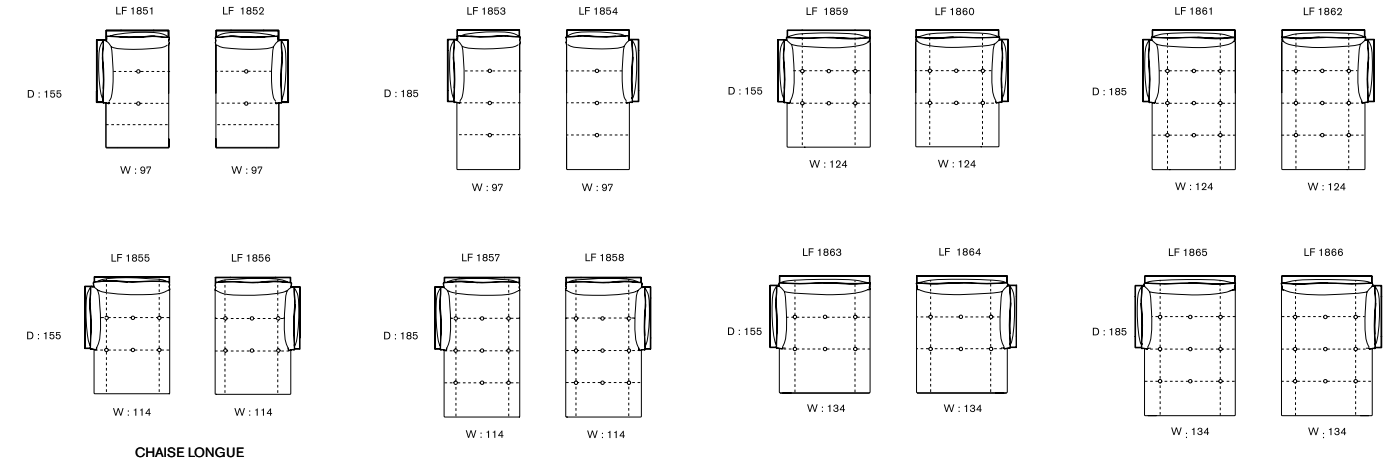
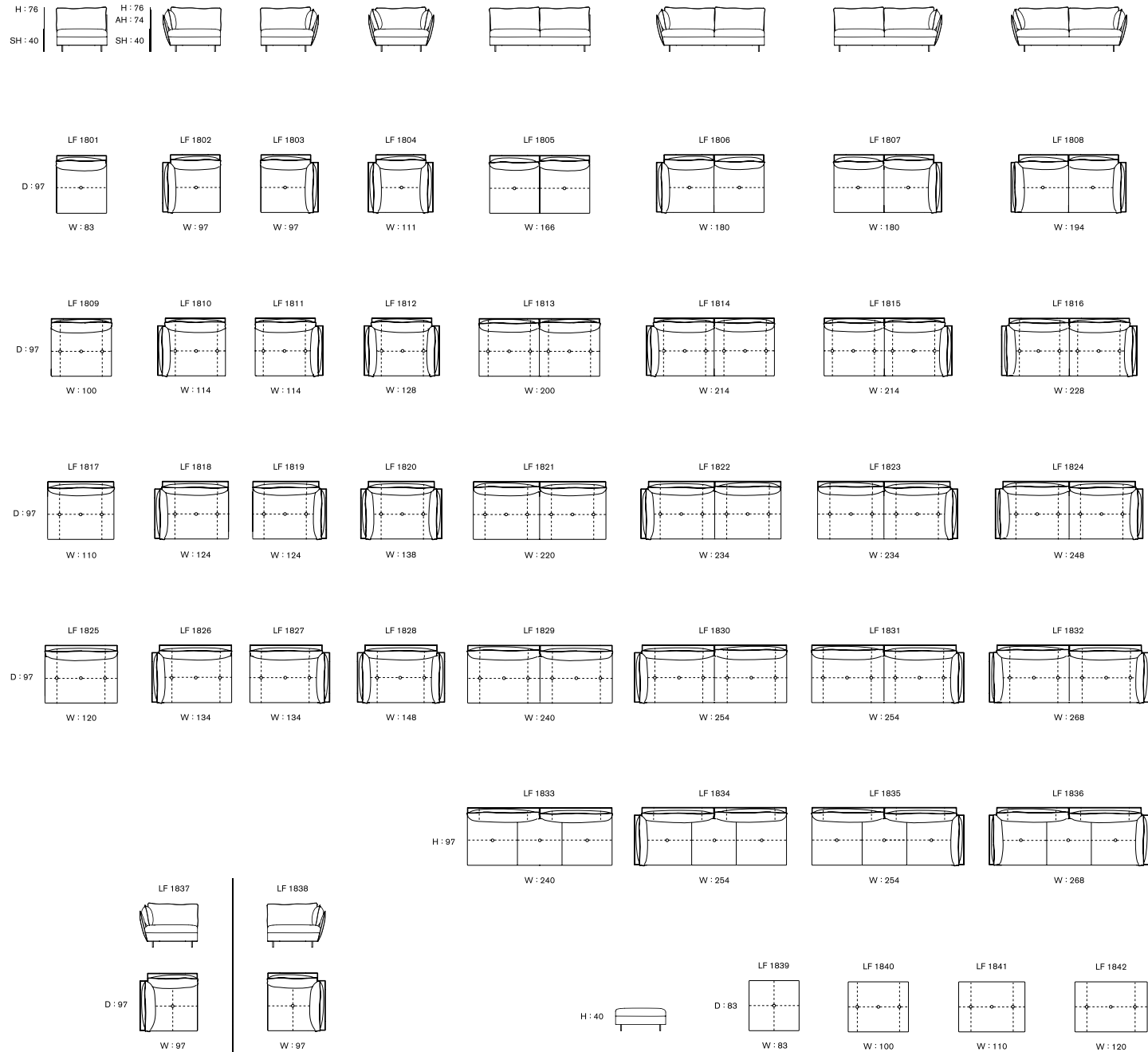

**CHAISE LONGUE**

74 |

**DIANA**

Design: SHINSAKU MIYAMOTO

Seat and back in removable fabric and leather

Frame cover in removable fabric and leather

Frame in walnut, oak

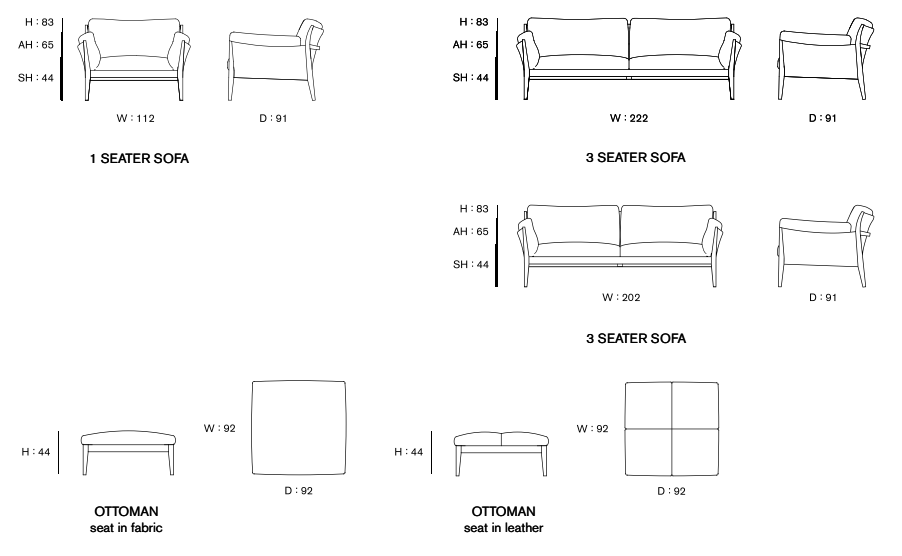

**1 SEATER SOFA**

**3 SEATER SOFA**

**3 SEATER SOFA**

**OTTOMAN seat in fabric**

**OTTOMAN seat in leather**

08 |

**LEEWISE EXCLUSIVE**

Design: JUNICHIRO WATANABE & RITZWELL  
 Seat and back cushion in removable fabric and leather  
 Wooden base frame structure in white ash  
 - - - - Sewing scheme in leather

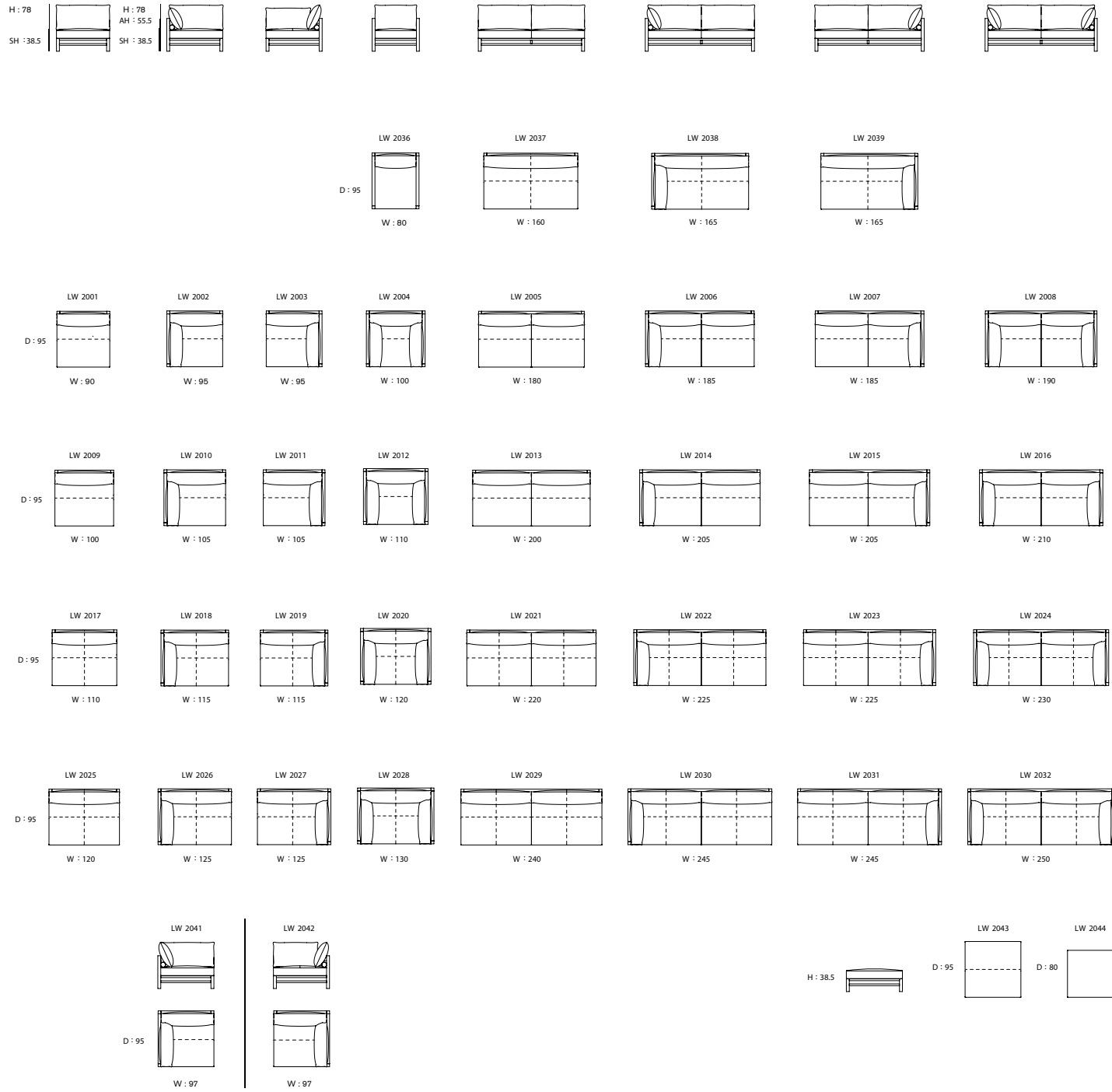

08 |

**LEEWISE EXCLUSIVE**

Design: JUNICHIRO WATANABE & RITZWELL  
 Top in oak  
 Leg frame in white ash

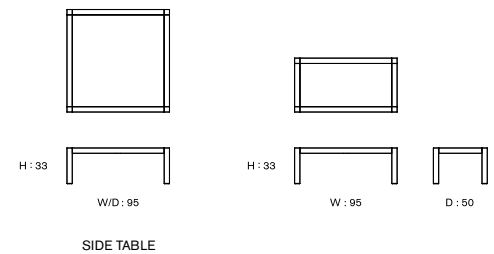
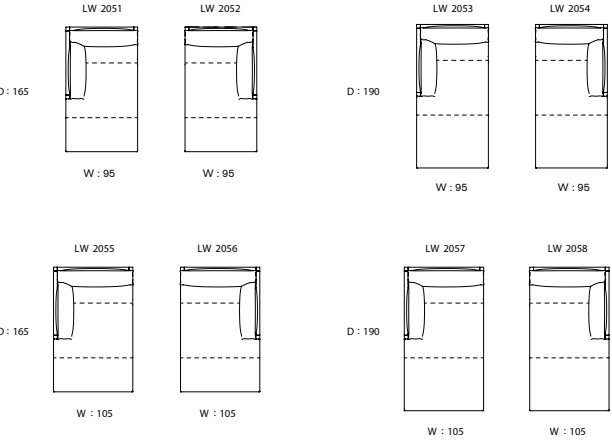

40 |

**JK TABLE**

Design: JUN KAMAHARA  
 Top in solid walnut  
 Leg in steel powder coating with black and hairline stainless steel acrylic urethane coating with 6 colors, classic rose, shiny brass, antique brass, shiny bronze, antique gray and shiny hairline

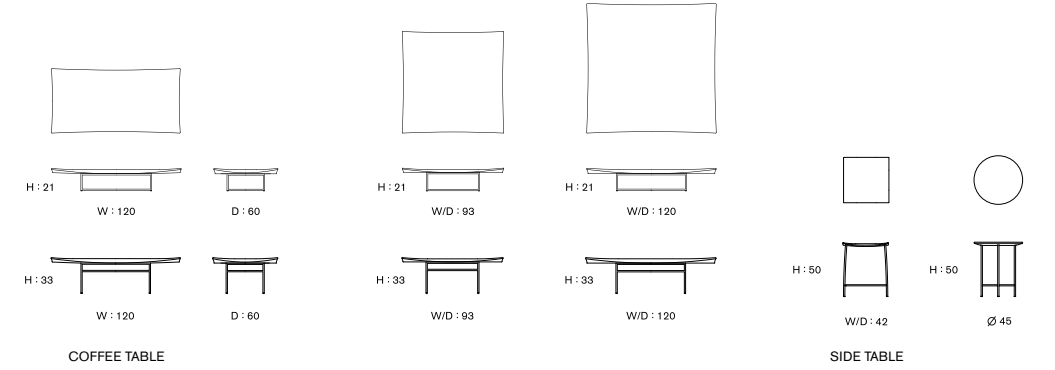

64 |

**MCM TABLE**

Design: SHINSAKU MIYAMOTO  
 Top and leg in solid walnut  
 Frame in steel powder coating with black



16 | 14 |

**MO TABLE**

Design: SHINSAKU MIYAMOTO  
Top in solid oak, walnut  
Leg in solid oak

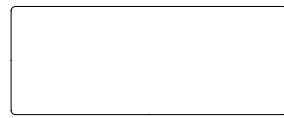
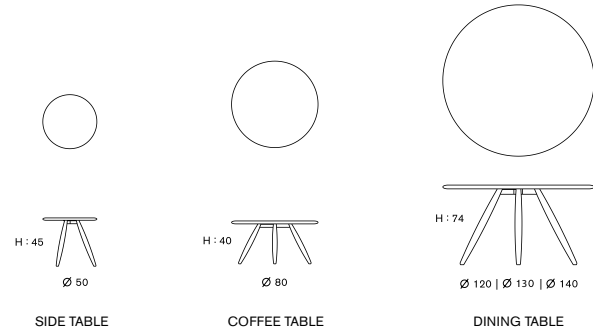

W : 205 | W : 225 | W : 255

D : 100

DINING TABLE

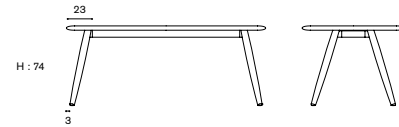
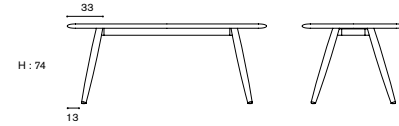
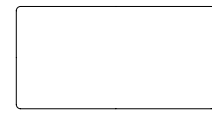

W : 145 | W : 165 | W : 185

D : 95

DINING TABLE

10 |

**MT TABLE**

Design: SHINSAKU MIYAMOTO  
Top in solid oak, walnut  
Leg in solid oak  
Frame in steel powder coating with black and hairline stainless steel acrylic urethane coating with 6 colors, classic rose, shiny brass, antique brass, shiny bronze, antique gray and shiny hairline

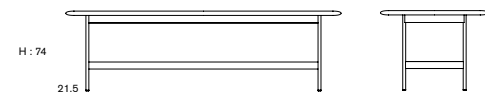
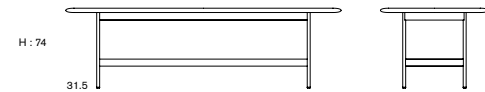
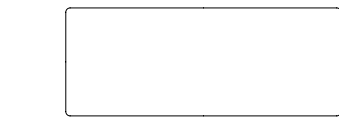

W : 205 | W : 225 | W : 255

D : 100

DINING TABLE

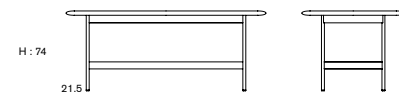
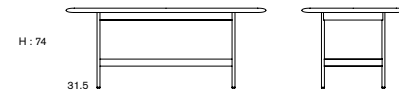
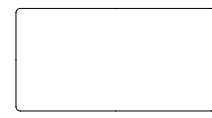

W : 145 | W : 165 | W : 185

D : 94

DINING TABLE

60 |

**OS TABLE**

Design: RITZWELL  
Top in solid walnut, oak  
Leg in steel powder coating with black and hairline stainless steel acrylic urethane coating with 6 colors, classic rose, shiny brass, antique brass, shiny bronze, antique gray and shiny hairline



SIDE TABLE

30 |

**JABARA SIDEBOARD**

Design: SHINSAKU MIYAMOTO  
Body in walnut, oak  
Base in steel powder coating with black and hairline stainless steel acrylic urethane coating with 6 colors, classic rose, shiny brass, antique brass, shiny bronze, antique gray and shiny hairline  
Door in sliding tambour door  
Front drawer in black, burgundy, vintage brown, taupe gray and dark brown thick leather.

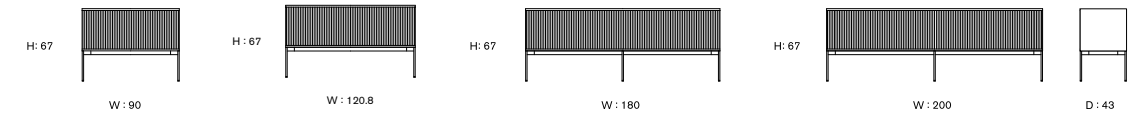
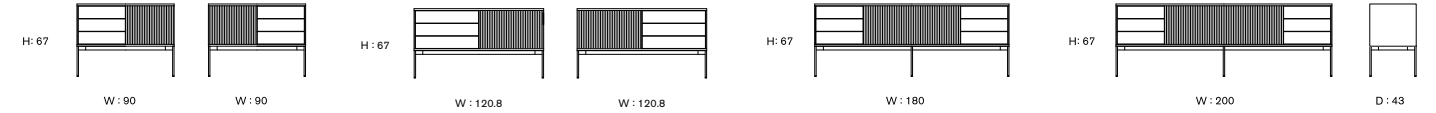
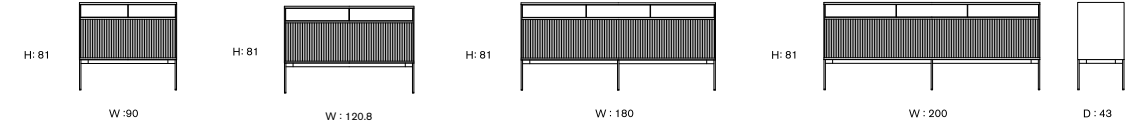

34 |

**JABARA AV BOARD**

Design: SHINSAKU MIYAMOTO  
Body in walnut, oak  
Base in steel powder coating with black and hairline stainless steel acrylic urethane coating with 6 colors, classic rose, shiny brass, antique brass, shiny bronze, antique gray and shiny hairline  
Door in sliding tambour door and glass flap door

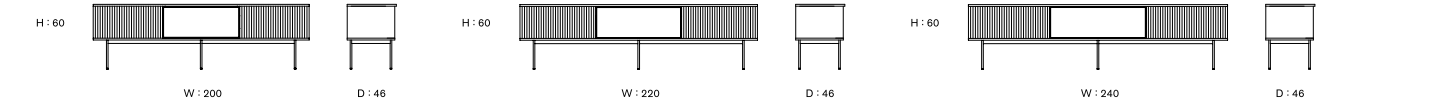
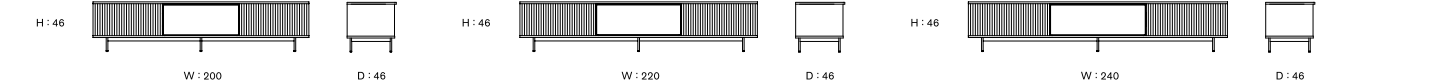
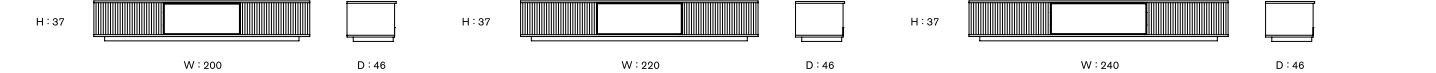
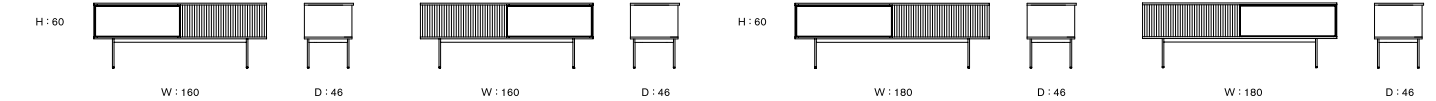
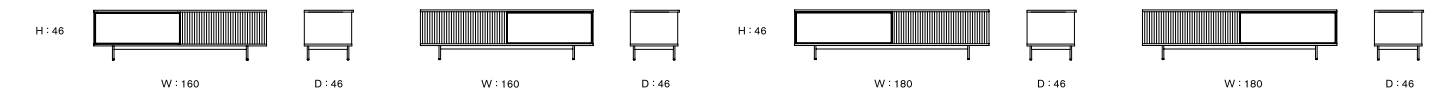
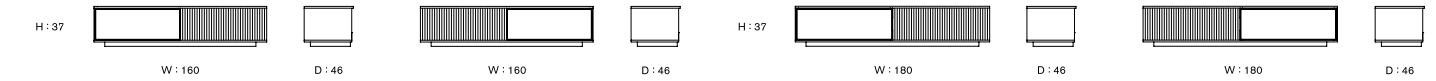



reddot design award  
best of the best 2019



reddot design award  
winner 2019



reddot design award  
winner 2018

AS AWARDED BY THE DESIGN ZENTRUM NORDRHEIN WESTFALEN E.V.



AS AWARDED BY iF INTERNATIONAL FORUM DESIGN GMBH



GERMAN DESIGN AWARD WINNER 2019  
GERMAN DESIGN AWARD SPECIAL 2019

AS AWARDED BY THE GERMAN DESIGN COUNCIL, THE AUTHORITATIVE GERMAN



archiproducts  
DESIGN AWARDS  
WINNER 2018



archiproducts  
DESIGN AWARDS  
WINNER 2019



archiproducts  
DESIGN AWARDS  
WINNER 2020

AS AWARDED BY ARCHIPRODUCTS



THANKS FOR THE LIGHTING:

Roll & Hill, suspension light Agnes Chandelier | 10

Tooy, suspension light Lilly and table light Macao | 14

Tooy, suspension light Osman 560.17 | 62

Ingo Maurer, floor light Wo-Tum-Bu1 | 62

Nahoor, table light KW | 62

Lumina, desk light Flo | 62

Roll & Hill, suspension light Modo Chandelier | 65-66

Paolo Castelli S.p.A., floor light For Hall Lamp | 72

Photo credits: Alberto Strada | 16

#### GRAPHIC DESIGN

UNTITLED-AGENCY Milano

#### PRINTED IN ITALY

ROTOLITO S.p.A.

# Ritzwell

RITZWELL & CO. | TOKYO | OSAKA | FUKUOKA

RITZWELL ITALIA S.R.L. | MILANO

info@ritzwell.com | www.ritzwell.com

